

# 4-H NEWSLETTER

October 2020



LINCOLN COUNTY  
COLORADO STATE UNIVERSITY  
EXTENSION

326 8th St., PO Box 68  
Hugo, CO 80821  
Phone: (719) 743-2542  
Fax: (719) 743-2555  
Website:

[lincoln.extension.colostate.edu](http://lincoln.extension.colostate.edu)

Facebook: [Lincoln County Colorado Extension](https://www.facebook.com/LincolnCountyColoradoExtension)

Robin Halley-Director, 4-H Youth Development/ Agriculture Agent  
[robin.halley@colostate.edu](mailto:robin.halley@colostate.edu)

Christine Schinzel-  
4-H Program Assistant  
[christine.schinzel@colostate.edu](mailto:christine.schinzel@colostate.edu)

Amy Solomon-  
Extension Program Assistant  
[coopext\\_lincoln@mail.colostate.edu](mailto:coopext_lincoln@mail.colostate.edu)

## INSIDE:

2020 F-150 Pick-up Raffle & Just To Get You Thinkin..	2
Enrollment Reminders	3
Information & Events & Family & Consumer: Cybersecurity	4-5
Safety Step Up: Prescription Opioid Safety & Youth- COVID-19	6-9
Activity Page	10
Calendar & Club Information	11
4-H's	12



## National 4-H Week Activities:

- ◆ #Opportunity4All Video Challenge-Submit a video link (2minutes or less) on what "Opportunity4All" means to you.
- ◆ Color Contest- Youth ages 3-9 submit a coloring page to be entered. Coloring Pages Link: <https://drive.google.com/file/d/1Yreu6VxLfeyX4ZrfdTtkdHC326QKYSR0/view?usp=sharing>
- ◆ Show your @4-H pride by wearing green or the 4-H clover on Wednesday, October 7th. Youth and adults post or submit a picture wearing your 4-H gear.
- ◆ Print off a 4-H'er Lives Here sign to post at your house to showcase your 4-H pride. Link: [https://drive.google.com/file/d/1mSnUKBR6atLsAqKF9\\_yT8kZDgNVgt54s/view?usp=sharing](https://drive.google.com/file/d/1mSnUKBR6atLsAqKF9_yT8kZDgNVgt54s/view?usp=sharing)
- ◆ 4-H Trivia Questions Challenge- Open to youth and adults. Link: [https://drive.google.com/file/d/14n2n8UeTGuKWROb\\_2-VLLIBHRPWxHO02/view?usp=sharing](https://drive.google.com/file/d/14n2n8UeTGuKWROb_2-VLLIBHRPWxHO02/view?usp=sharing)
- ◆ 4-H Alumni share your favorite memory that demonstrates how @4-H provided you with opportunities to become the person you are today.

Check out the [Lincoln County Colorado Extension Facebook Page](https://www.facebook.com/LincolnCountyColoradoExtension) October 4-10 for activity items. *\*Activity submissions can be uploaded in the comment section for each days Facebook post or sent to [christine.schinzel@colostate.edu](mailto:christine.schinzel@colostate.edu) by October 10th. Submissions will be entered into drawings for 4-H items.*

# 2020 4-H FORD F-150 PICK-UP & CASH RAFFLE

The Lincoln County 4-H Council is selling truck raffle tickets this year through an online purchase platform only, due to Covid-19. Part of the ticket sales proceeds directly benefits the Lincoln County 4-H program. The remaining funds go to the State 4-H Foundation to provide support state-wide in the form of programming, scholarships, grants, and awareness.

The link to purchase tickets to benefit Lincoln County 4-H members is:

**Lincoln County 4-H Council Online Purchase Link:** <https://go.eventgroovefundraising.com/fordtruckraffle/lc4h>

Tickets are \$5 each or 5 for \$20. \*There is a small processing fee for online purchases that will be added to the total.

*Drawing for the 2020 truck will be at the Beef Expo on November 19, 2020 at The Ranch Events Complex in Loveland, CO. \*Need not be present to win.*

*The raffle truck is sponsored by the Ford Dealers of Colorado Association!*

*Colorado 4-H Foundation Raffle Information:*

<https://co4hfoundation.extension.colostate.edu/>

*2020 County Council Members: (Liliana Borders, Elivia Hilferty, Jiggs Parker, Kayla Schier, Daisy Stone, Paige Beedy, Elizabeth Schier, Lyndee Yoder, Tailyn Thompson, and Tristan Lindt )*



## JUST TO GET YOU THINKIN...

*"The way I see it, if you want the rainbow, you gotta put up with the rain."*

*-Dolly Parton*

*"Most folks are as happy as they make up their minds to be."*

*-Abraham Lincoln*

# NEW YEAR 4-H ENROLLMENT REMINDERS:

## Enrollment Deadlines:

November 1-Enrollment Opens.

December 1-Enrollment closes for returning members, foundation members, & volunteers.

January 1-Enrollment closes for new members.

## Project Deadlines:

March 1-Project add/drop.

\*Hunter's safety must be completed for all members enrolled in shooting sports projects or they will be dropped at this date.

\*Livestock will have to be tagged and/or nominated to be eligible to show at fair. Information will be posted in the newsletter for current year information.

## Other Deadlines/ Project Requirements:

\*Refer to the fair book for project requirements to show at fair and download a record book for completion requirements as well.

\*Watch for information in the newsletter, Facebook page [Lincoln County Colorado Extension](https://www.facebook.com/LincolnCountyColoradoExtension), or calendar [lincoln.extension.colostate.edu/events/](https://lincoln.extension.colostate.edu/events/).

## Information Required for 4-H Enrollment Approval:

-Verify your eligibility for enrollment in Lincoln County. *Requirements include one of the following: reside/own property in the county, attend school in the county, or live within 10 miles of the county line. To enroll members must be between the ages of 8-18 as of December 31.*

-Enrollment must be completed in your 4H Online account. \*4H Online updated to a new version and the system will look different.

-Complete the health form, including the physical and insurance section. \*If you do not have health insurance, please put (None). Everyone must still sign this form. The form is required to participate in all 4-H.

-Complete the t-shirt size and other release forms (i.e. Covid release).

-Complete emergency contacts (must be different from the parents).

-Update your mailing address, phone numbers, and preferred email.

\*Email is the primary mode of communication from the office. The primary account listed will be the one receiving messages.

-Refer to the Colorado 4-H project page to verify you are enrolling in the correct project. \*Hunter's Safety is required for all members participating in shooting sports.

-Remember to read each page carefully, select options, and electronically sign and date all sections in 4H Online before clicking to the next page. \*You cannot return to a previous page.

\*Enrollments for members and volunteers cannot be approved until all required information has been completed. Please email or call the office if you have any questions.

## Resources:

Lincoln County 4-H- [lincoln.extension.colostate.edu/programs/4-h/](https://lincoln.extension.colostate.edu/programs/4-h/)  
Colorado 4-H- [co4h.colostate.edu/](https://co4h.colostate.edu/)

## Enrollment/Project Fees:

-Enrollment fee- \$18/member (Pay fee to the club directly).

-Late enrollment fee-\$20/member payable directly to the Extension office. \*This is in addition to the \$18 regular fee paid.

-Shooting Sports members- \$25/per enrolled shooting sports discipline. (This is in addition to the enrollment fee and is payable to the Extension office directly.)

\*\*Other projects may require additional fees or expenses. There are no fees for leaders or volunteers.

# INFORMATION & EVENTS

County: *Reminder to check your email and monitor our Facebook page for updates on 4-H activities and events. \*\*Forms, Fees, and registrations are due to office by (day stated) or (previous Friday) if day is a weekend or holiday. County related forms and applications are available on the 4-H Forms & Applications page at [lincoln.extension.colostate.edu/4-h-forms-applications/](http://lincoln.extension.colostate.edu/4-h-forms-applications/). A reminder that forms can be mailed, emailed, or faxed to the office, as well as dropped through the back door slot.*

- ◆ **4-H Enrollment** begins in November and ends December 1 for returning 4-H members and volunteers. A \$20 late fee applies to late re-enrollments. New members may enroll until January 1.
- County Clubs Information: [lincoln.extension.colostate.edu/programs/4-h/clubs-councils/](http://lincoln.extension.colostate.edu/programs/4-h/clubs-councils/)
- 4-H Member in Good Standing Requirements: [lincoln.extension.colostate.edu/4-h-policy-guidelines/](http://lincoln.extension.colostate.edu/4-h-policy-guidelines/)
- 4-H Club/County Transfer/Eligibility: [lincoln.extension.colostate.edu/4-h-policy-guidelines/](http://lincoln.extension.colostate.edu/4-h-policy-guidelines/)
- ◆ **Livestock Sale Committee (Livestock Scholarship Program Beef)** applications are due November 1. Goat, swine, and sheep applications are due February 1. For specific program information and an application go to [lincoln.extension.colostate.edu/4-h-forms-applications/](http://lincoln.extension.colostate.edu/4-h-forms-applications/) and look under "livestock sale".
- ◆ **Shooting Sports**-All members interested in taking shooting sports next year need to be sure and obtain their Hunter's Safety Card before the March 1 add/drop project deadline. Interested shooting sports members also need to remember to take a look at their shell inventory and start planning for purchases for next season as well. *\*\*Until November 14th- CPW is allowing individuals 11+ to take the certification course entirely online. In-person classes have been suspended for now due to Covid. For updated information and certification classes go to [cpw.state.co.us/learn/Pages/HunterEducation.aspx](http://cpw.state.co.us/learn/Pages/HunterEducation.aspx).*

## Other

*\*\*\*Verify with listed contacts pertaining to their individual event to find out specific information and guidelines, event cancellations procedures, registration requirements, etc.*

- ◆ **Colorado Simmental Youth Herd Builder; Education; & Fair Grants & Scholarships** applications are due October 1. Information is available at [coloradosimmental.com](http://coloradosimmental.com).
- ◆ **National 4-H Week is October 4-10.** Check out the Extension Facebook page for activities.
- ◆ **D2BY South Central Youth Camp** is tentatively set for October 31 in Kiowa for 4-H youth ages 10-13 to participate in day workshop activities. Other details TBD. Interested youth need email Christine.schinzel@colostate.edu by October 14th to RSVP.
- ◆ **Lincoln County Cattle Raiser's Education Day and Beef Quality Assurance certification** is open to adults and youth 14+ on October 23rd at the Lincoln County Fairgrounds. To register contact Christine at 719-743-2542 or Christine.schinzel@colostate.edu by October 14.



## INFORMATION & EVENTS

- ◆ **Colorado 4-H Shooting Sports Ambassador** application is due October 15 to Sam Lowry at [sam.lowry@colostate.edu](mailto:sam.lowry@colostate.edu). Information and the application is available at [co4h.colostate.edu/ss/forms/ambassador-application.pdf](http://co4h.colostate.edu/ss/forms/ambassador-application.pdf).
- ◆ **Colorado Farm Show Scholarships** are due November 1. For information and the application go to [coloradofarmshow.com/scholarship](http://coloradofarmshow.com/scholarship).
- ◆ **Farm to Virtual Fair Contest** is open to 4-H and FFA members to submit a livestock project photo and information per rules till November 2. For contest information go to [ncga.com/f2f](http://ncga.com/f2f).
- ◆ **Daniels Scholarship** application is available until November 15. For more information and application procedures go to [danielsfund.org/scholarships/index.asp](http://danielsfund.org/scholarships/index.asp).
- ◆ **National Dairy Herd Association Scholarship** is due November 30. Additional information is available at [dhia.org/scholarship.asp](http://dhia.org/scholarship.asp).
- ◆ **American Quarter Horse Association Scholarships** are due December 1. Additional information is available at [aqhfoundation.smapply.io/prog/aqhf\\_scholarship\\_program/](http://aqhfoundation.smapply.io/prog/aqhf_scholarship_program/).
- ◆ **Colorado Conservation Tillage Association Scholarship** application is open until December 1 at [highplainsnotill.com/scholarships/application.html](http://highplainsnotill.com/scholarships/application.html).
- ◆ **National Corn Growers Association & BASF Scholarship** application is due December 1. Information is available at [ncga.com/topics/education/college-scholarships](http://ncga.com/topics/education/college-scholarships).
- ◆ **National Sorghum Foundation-Joint BASF Scholarship** application is due December 1. Information is available at [sorghumgrowers.com/Foundation-Scholarships/](http://sorghumgrowers.com/Foundation-Scholarships/).
- ◆ **American Ranch Horse Scholarship** is due December 31. Additional information is available at [americanranchhorse.net/forms.asp#Youth Forms](http://americanranchhorse.net/forms.asp#Youth Forms).

## FAMILY & CONSUMER: CYBERSECURITY



### General Electronic Device Reminders for All:

- ◆ Limit access on Public WiFi; it is not secure and makes a great access point for criminals to steal your information.
- ◆ Invest in security software for all devices.
- ◆ Back up your information to an external drive on a frequent basis in case your device is hacked or frozen by criminals.
- ◆ Don't answer emails or phone calls regarding service to your device if you didn't initiate a request.
- ◆ Utilize passwords when logging into all devices (phone, tablet, computer, smart TV, etc.)

# Safety Step UP:

## Prescription Opioid Safety & Youth->COVID-19

Opioid addiction across the United States is a considerable problem. The National Institute of Drug Abuse indicates that roughly 2.5 million people currently suffer from opioid addiction; many of which are youth. Since the beginning of COVID-19 youth and families have encountered a number of challenges above and beyond the normal including: job losses; illnesses and loss of life; financial constraints; a lack of resources (education, food, health products, etc.); social restrictions; increases in abuse; closure of businesses and so much more. During this time it's important to help youth and families recognize that the continued ripple effect from these events could cause an increase of opioid or other illegal substance abuse by youth. Utilize the following information and resources to help keep everyone safe and prevent opioid addictions.



### Risk Factors For Potential Use During COVID-19

- Boredom or avoidance of current reality
- Isolation and depression
- Fear, anxiety, and/or stress
- Loss of life (friends, family, classmates)
- Loss or restrictions on activities or hobbies
- Reduced access to healthcare resources
- Parents or family members incurring increased workloads, reduced resources, lost incomes, etc.
- Ease of access to get opioids from the home or others

**Examples of Opioid Containing Medicines:** Cough Syrup with Codeine, Vicodin, Morphine, Tramadol, Buprenorphine, Oxycodone, and more.

### Warning Signs Youth May be Struggling:

- Loss of appetite or overeating compared to normal
- Avoidance of social engagements (in-person with family, on the phone, videoing, etc.)
- Loss of interest in activities and hobbies
- Poor self-care or drastic appearance changes
- Incomplete homework or a drop in grades
- Getting into trouble
- Drop off in care for pets
- Putting off important tasks
- Secretive behavior
- Frequent or large shifts in their mood
- Increased general illnesses (headaches, stomach aches, etc.) or faking symptoms
- Loss of a family or friend, job, etc.

# Safety Step UP:

## Prescription Opioid Safety & Youth->COVID-19 (Continued)

### Youth & Adults: Stronger Together

- Spend time talking about the crisis and changes (economically, emotionally, physically) and what's been lost as an (individual, family, community, etc.).
- Talk about positive ways to reduce stress and model that behavior to others.
- Reach out to friends to provide a listening ear; and remember it's okay to get adults involved to better help your friends (don't take on too much).
- Keep youth engaged by spending time doing activities/projects with them and talking. Limit time spent alone and get to know their friends and parents as well.
- Limit social media/technology use and keep those items out in a public portion of the house.
- Talk about resource hotlines and phone number available to get help for them or someone else.
- Talk to your children about over-the-counter medicines and prescriptions and their uses.
- Talk about poisoning and other side effects (physical/mental) from taking too much; using someone else's medication; or combining medication use with alcohol or other opioids.
- Remind them not to share medications with others or accept medications in return.
- Help keep everyone safe by keeping prescriptions out of sight and locked-up.
- Dispose of prescriptions according to instructions or at local pharmacies or law enforcement center drop boxes.

### Signals that someone may be misusing opioids in the household:

- Missing medications (over-the-counter or prescription).
- Behavioral or physical changes (outside of their normal demeanor).
- Avoidance of questions and increasing secretive behavior.
- Spending an abnormal amount of time in one location on the property.
- Missing cash or asking for additional spending money.



**Center for Disease Control (CDC) Opioid Overdose Symptoms:** small, constricted pupils; loss of consciousness; shallow or slow breathing; choking or gurgling sound; limp body; pale or blue or cold skin.

*If you encounter any of these symptoms in an individual or are unsure of their condition->*

**Call 9-1-1 Immediately!**

# Safety Step UP:

## Prescription Opioid Safety & Youth->COVID-19 (Continued)

### Warnings

**Liver warning:** This product contains acetaminophen. The maximum daily dose of this product is 8 tablets (4,000 mg) in 24 hours. Severe liver damage may occur if you take

- more than 4,000 mg of acetaminophen in 24 hours
- with other drugs containing acetaminophen
- 3 or more alcoholic drinks every day while using this product

**Allergy alert:** acetaminophen may cause severe skin reactions. Symptoms may include:

- skin reddening
- blisters
- rash

If a skin reaction occurs, stop use and seek medical help right away.

**Do not use** ■ with any other drug containing acetaminophen (prescription or nonprescription).

If you are not sure whether a drug contains acetaminophen, ask a doctor or pharmacist.

- if you have ever had an allergic reaction to this product or any of its ingredients

**Ask a doctor before use if you have liver disease**

**Ask a doctor or pharmacist before use if you are taking the blood thinning drug warfarin**

**Stop use and ask a doctor if**

- pain gets worse or lasts more than 10 days
- fever gets worse or lasts more than 3 days
- new symptoms occur
- redness or swelling is present

These could be signs of a serious condition.

**Note: This image does not show a complete Warnings section.**

Common (Over-The-Counter)  
Medicine Label

### Dig Deeper Activity:

Pull out prescription and over the counter medicine labels at your home and talk to youth about the what the different parts of the label mean and their importance.



Common Prescription  
(Rx) Label

### True or False Fact Check-In:

- 1) T or F Serious health complications can occur when prescriptions are not taken as prescribed.
- 2) T or F It's easy to tell pills apart and you can combine similar colors or sizes.
- 3) T or F Opioids are not addictive.
- 4) T or F It's never okay to misuse or illegally use opioids; even if my friends are doing it.
- 5) T or F I can give my pills to others when I am done with them.
- 6) T or F Prescriptions and over-the-counter medications should always be locked up.

Answers: 1) T, 2) F-Color or size will not tell you what the pill is, 3) F-They can be addictive, 4) T, 5) F-It's illegal and extremely dangerous to other's health to give them your prescriptions, 6) T



# Safety Step UP:

## Prescription Opioid Safety & Youth->COVID-19 (Continued)

### Say "No" to Drugs Color & Short Story Activity:

Use a blank page to draw a picture about what saying "No" to (prescription misuse or other drugs) looks like to you and write a short story to go with your picture.

Then share how you will "Say No to Drugs" with your family and friends!

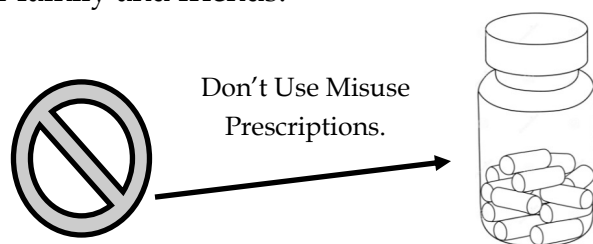

### Bonus Activity->

**How Am I Doing-Daily Check-In:** \*Use a mirror, journal, or a magnetic whiteboard in your locker to do a daily check-in of how it's going. *Be sure to ask for help when it all becomes too much!*

- \_\_\_ It's a Great DAY!!!
- \_\_\_ Lot Going On-But Still Going!
- \_\_\_ Not as Good Today.
- \_\_\_ I'm becoming overwhelmed.
- \_\_\_ I NEED HELP NOW.

### ~ Resources ~

- ◆ **Center for Disease Control (Opioid Resources):** [cdc.gov/drugoverdose/patients/materials.html](https://www.cdc.gov/drugoverdose/patients/materials.html)
- ◆ **Colorado Crisis Service:** [coloradocrisisservices.org/](https://coloradocrisisservices.org/) or **CALL 1-844-493-TALK (8255)** or **TEXT TALK TO 38255**
- ◆ **Colorado Department of Human Health Resources** (mental health, help hotlines and local physical locations, addiction resources, Medicaid resources, and veterans): [colorado.gov/pacific/cdhs/find-behavioral-health-help](https://colorado.gov/pacific/cdhs/find-behavioral-health-help)
- ◆ **FarmTownStrong** (Rural and Ag Producer Opioid Resources): [farmtownstrong.org/](https://farmtownstrong.org/)
- ◆ **Food & Drug Administration-Medicine Disposal:** [fda.gov/drugs/safe-disposal-medicines/disposal-unused-medicines-what-you-should-know](https://www.fda.gov/drugs/safe-disposal-medicines/disposal-unused-medicines-what-you-should-know)
- ◆ **National Institute on Drug Abuse & Youth Resources:** [drugabuse.gov/](https://www.drugabuse.gov/)
- ◆ **Partnership for Drug-Free Kids:** [drugfree.org/landing-page/get-help-support/](https://www.drugfree.org/landing-page/get-help-support/) or **Call 1-855-378-4373**
- ◆ **Poison Control:** [poison.org/](https://www.poison.org/) or **CALL 1-800-222-1222** or [triage.webpoisoncontrol.org/#/exclusions](https://www.triage.webpoisoncontrol.org/#/exclusions)
- ◆ **Substance Abuse & Mental Health Administration:** [samhsa.gov/](https://www.samhsa.gov/) or **CALL 1-800-662-HELP (4357)** or Disaster Distress Hotline **CALL 1-800-985-5990**

# ACTIVITY PAGE:

## Monthly Reader:

### *The Prized Pumpkin*

By Rick Henningfeld

Draw a Line to Match up Parts of the Mower &  
Color the Mower:

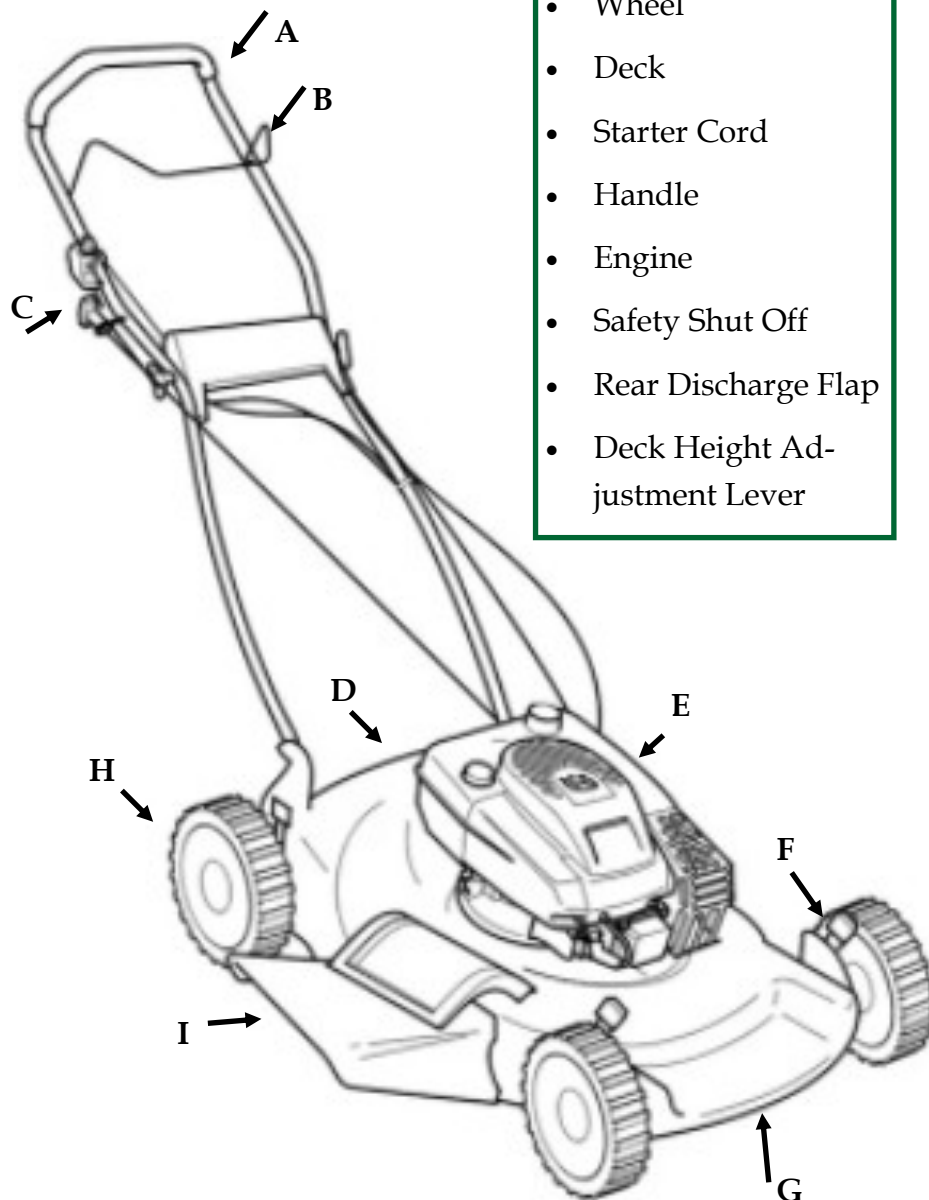

- Wheel
- Deck
- Starter Cord
- Handle
- Engine
- Safety Shut Off
- Rear Discharge Flap
- Deck Height Adjustment Lever

**Baking Fun:** Check out this Frosted Pumpkin Cookie recipe by Samantha at [spendwithpennies.com/wprm\\_print/121731](http://spendwithpennies.com/wprm_print/121731). This a great way to use of some of the pumpkins out of the garden and get the kids involved in decorating for Halloween or other fall events.

**Fall Clean-Up:** This fall is a great time to clean up your own yard or help someone else clean up all of the fall leaves and other debris. Not only do you get to help someone else, but you also get to enjoy some fresh air in the great outdoors and boost your physical activity. You can also have a contest with your neighbors by bagging up all the leaves and seeing who has the most overall and individually which bag was the heaviest.

- Bonus- Fill in The Blank: 1) The mower blade is located \_\_\_\_\_
- 2) The mower bag connects to the \_\_\_\_\_.
- 3) Where can grass come out of the mower after being cut?  
\_\_\_\_\_

# October 2020

Sun	Mon	Tue	Wed	Thu	Fri	Sat
				1	2	3
4	5	6	7	8	9	10
National 4-H Week (October 4-10)!						
11 Heart- land Club Zoom Mtg.	12 <i>Holiday</i> - Office Closed	13	14 RSVP Due D2BY Camp	15	16	17
18	19	20	21	22	23	24
25	26	27	28	29	30	31 D2BY Day Camp
New Year 4-H Enrollment will open starting in November and close December 1!						
Livestock Scholarship Program Beef Applications are due November 1						

## 4-H CLUB INFORMATION:

### *Rocking 4-H Club*

Club Information: Meets in Limon

Club Leader: Jodi Hilferty



### *Karval 4-H Club*

Club Information: Meets in Karval  
Club Leader: Nikki Reid

### *Kountry Kids 4-H Club*

Club Information: Meets in Hugo  
Club Leader: Ryan Bush

### *Heartland 4-H Club*

Club Information:  
Meets in Arriba  
Club Leader: Renae Saffer

### *Walk's Camp 4-H Club*

Club Information: Meets North  
of Limon  
Club Leader: Cheryl Thompson

## Head-> USDA-FCIC

The Risk Management Agency (RMA) houses the Federal Crop Insurance Corporation (FCIC) program. The first federal crop insurance program dates back to the 1930's. Since then the program has gone through many changes including producer requirements and products offered. FCIC today provides standard and new insurance products to help producers reduce their operational risk and provide for catastrophic level insurance in some cases. To learn more about the FCIC program and local providers of insurance products go to: [rma.usda.gov/Topics/Insurance-](http://rma.usda.gov/Topics/Insurance-)

## Hands-> Shopify: Business Resource

Home-based (direct-to-consumer) businesses continue to gain in popularity. As such their need for customizable resources for marketing, inventory, and accounting has also increased. One company that is helping these smaller business is Shopify. Their focus is providing a one-stop shop for businesses to integrate their in-person sales with online sales and being able to manage that. This also includes support for marketing, points of sale, inventory, shipping, payments, item branding, other app integration, courses, tools, and more. Check out this company and others about how to integrate your business at [shopify.com](http://shopify.com). A current company using their site template is available to see at [cornerpostmeats.com/](http://cornerpostmeats.com/).

## Heart-> Sponsor Equipment for a 4-H Project

The new 4-H year is just around the corner and soon new and returning members will be choosing 4-H projects to complete in the new year. As you are thinking about the projects you will enroll in for the year also take some time to inventory learning manuals, equipment, and left-over project resources. Consider if you will be using any of these resources going forward and which resources will no longer be utilized. This could be a great opportunity to reach out to other members and see if they would have an interest in utilizing those resources or equipment to help them in the upcoming year with their project. You may also consider sponsoring the purchase of equipment or materials for another members project to help get them started this coming year.

## Health-> USDA Seasonal Produce Guide

The United States Department of Agriculture (USDA) provides many resources for consumers including the Seasonal Produce Guide. The guide allows users to select different produce types to find what seasons they typically grow in; check out nutritional facts; learn how to use the produce item; provides recipe inclusion ideas; selection and storage facts; farmers market information relating to Snap-Ed benefit use; and more. To check out this great tool and learn more about when produce might be in-season in your area go to [snaped.fns.usda.gov/seasonal-produce-guide](http://snaped.fns.usda.gov/seasonal-produce-guide).

Colorado State University, U.S. Department of Agriculture and Lincoln County cooperating.

Extension programs are available to all without discrimination.

Any mention of company names and/or products doesn't imply an endorsement of those entities or their services nor does it imply a criticism of their competitors and products. Items mentioned are strictly for educational purposes.